

Stealth-XG Welding/Grinding Helmet & Digi-Air PAPR Combination



Part No.	Description
6044	Welding and Grinding PAPR System
6044BT	Welding and Grinding PAPR System – Blue Tooth

TRUECOLOUR LENS

HELMET FEATURES

- Lightweight, ergonomic design with high impact resistance material
- Flip up with large clear view for grinding/cutting
- All-around head protection
- Fast and easy switch between Grinding and Welding
- Simple in/out structure for convenient replacement of external cover lens
- User-friendly remote design with wireless interface and OLED display
- Multi-featured interface menu provides easy and quick ADF setting
- Remote can either be locked on helmet or taken off
- Environmentally friendly rechargeable Li-ion battery design
- No battery replacement needed.
- Lightweight, slim compact design to reduce fatigue and increase comfort
- The ADF is 27% thinner and 20% lighter
- Unprecedented true colour technology provides a true visual world
- Supplied with a carrying bag

ADF LENS FEATURES

CE Classification	1/1/1/1
True Colour	Yes
View Size	100 x 60mm
Arc Sensor	4
Shade Range	4/5-9/9-13
Delay Range	0.1-0.9s
Shade number of POWER OFF state	3.6#
Power On/Off	Fully Automatic
Adjustment Mode	Wireless remote control
Switching Time	0.08ms
Grinding Function	Yes
Cutting Function	Yes, Shade 5#-8# adjustable
Low Battery Indicator	Yes
Low Amperage TIG Rated	3A
Power Supply	Solar cell, Li-ion rechargeable
Certification	CE, ANSI, CSA, AS/NZS
Display	OLED
Mode Setting	Press and Turn
Short Press (<1s)	Shade → Sensitivity → Delay Time
Long Press (>1s)	Welding → Grinding → Cutting
Power Supply	Li-ion rechargeable
Battery Chargeable time	>500 times

Stealth-XG Welding/Grinding Helmet & Digi-Air PAPR Combination – Spare Parts

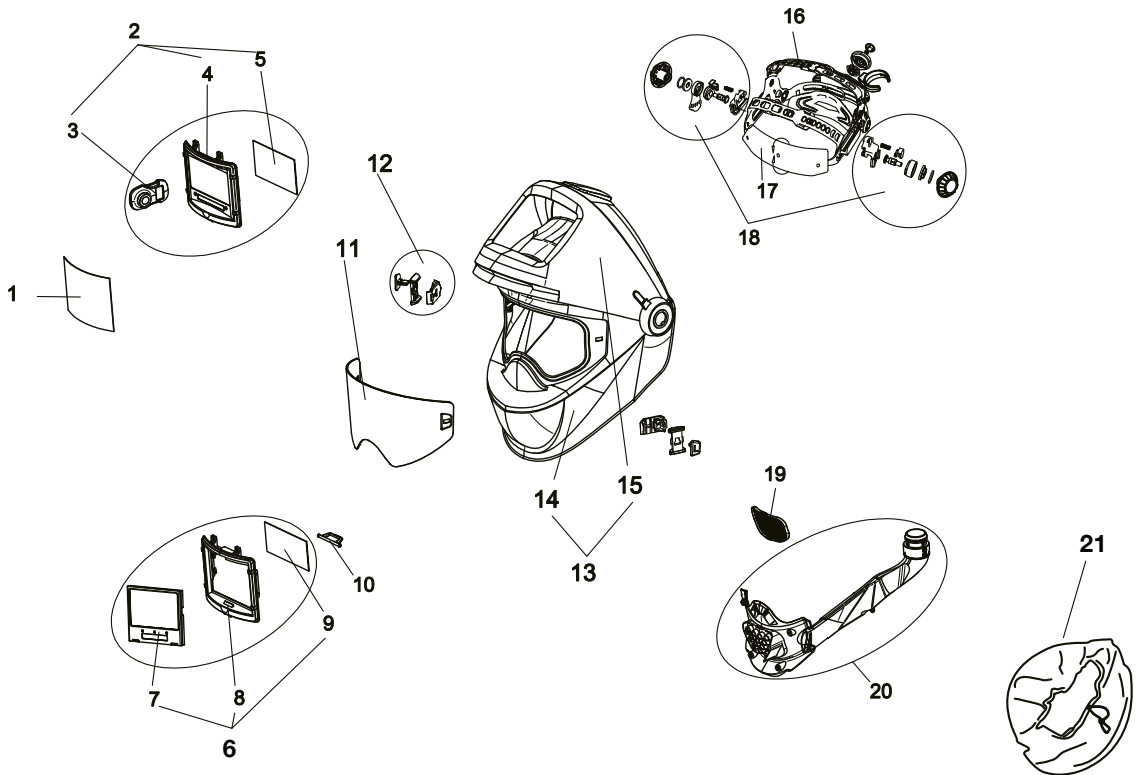

STEALTH-XG 6044 HEADTOP PARTS LIST

Figure	Part No.	Description
1	3026	Outer protection lens 118 x 97 x 1 mm
2	6044-02	Blue Tooth ADF Set
3	6044-03	Blue Tooth Remote control
4	6044-04	Blue Tooth ADF (without Remote control)
5	6044-05	Inner protection lens 104.5 x 64 x 1 mm
6	6044-06	True Colour ADF Set
7	6044-07	True Colour ADF
8	6044-08	ADF Frame
9	3021	Inner protection lens 105.8 x 65.8 x 1 mm
10	6044-10	ADF Lock
11	6044-11	Grinding visor
12	6044-12	Slider lock unit
13	6044-13	Helmet
14	6044-14	Helmet Shell (A)
15	6044-15	Helmet Shell B
16	6044-16	Headgear
17	6044-17	Sweatband
18	6044-18	Headgear Fasteners
19	6044-19	Dust Screen
20	6044-20	Airduct
21	6044SEAL	Face Seal

PAPR PARTS LIST – See page 291 for diagram

Part No.	Description
3044HOSE	Breathing Hose
3044COV	Breathing Hose Cover
3044TEST	Air Flow Tester
3044CHA	Battery Charger
3044HARN	Shoulder Harness
3044BLT	Waist Belt
4044COV	Filter Cover
3044GAU	Gauze Filter
3044PRE	Pre-filter
3044P3	Filter
3044BLOW	Turbo Unit
3044BAT	Rechargeable Battery

Safety & PPE